

BASIC INFORMATION ABOUT THE PRODUCT



- As many as 36 models differing in heating power (9, 11, 14, 16, 19 and 25 kW), glazing (straight or corner) and door opening method (traditional or lifted up).
- Possibility of any modification of the glazing and selecting the Decor, curved glass or double glazing option.
- Inserts made of high-quality P265GH boiler steel, which is resistant to continuous operation at elevated temperatures. A reinforced door profile was used.
- Production is carried out using a modern fleet of machines: welding robots, press brakes, laser cutting machines.
- It meets restrictive exhaust emission standards and the ECODSIGN directive thanks to the use of an exhaust gas after-combustion system and high efficiency.
- The innovative ventilated handle protects against burns. Suitable for houses with heat recovery.
- A built-in intake with a damper allows for smooth, integrated regulation of the amount of air supplied.
- The air curtain provides a „clean glass“ effect, and easy cleaning is provided by a cast iron grate with a removable ash container.

Nominal power [kW]	11
Heating load range [kW]	5,5-14
Thermal efficiency [%]	83
CO emission (at 13% O ₂) [g/m ³]	0,038
Pollen emission [g/m ³]	1,243
Average fuel consumption [kg/h]	3
Recommended dimensions of outlet grilles [cm ²]	770-88
Recommended dimensions of inlet grilles [cm ²]	440-720
Glass dimensions [mm]	590x430
Flue diameter [mm]	197
Inlet diameter [mm]	123
Weight [kg]	124
Efficiency factor	111,4



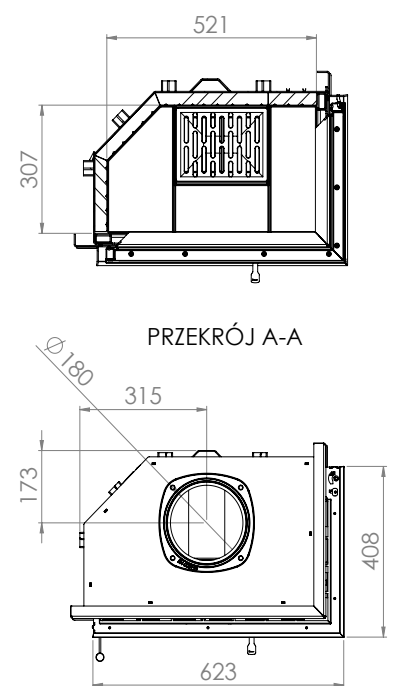
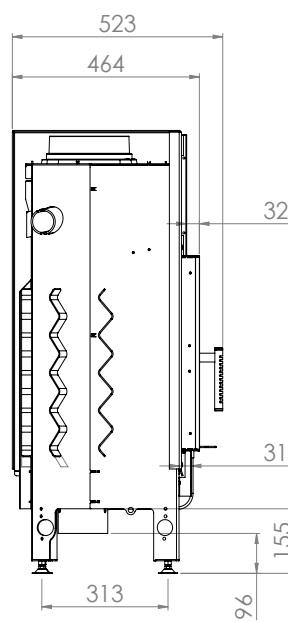
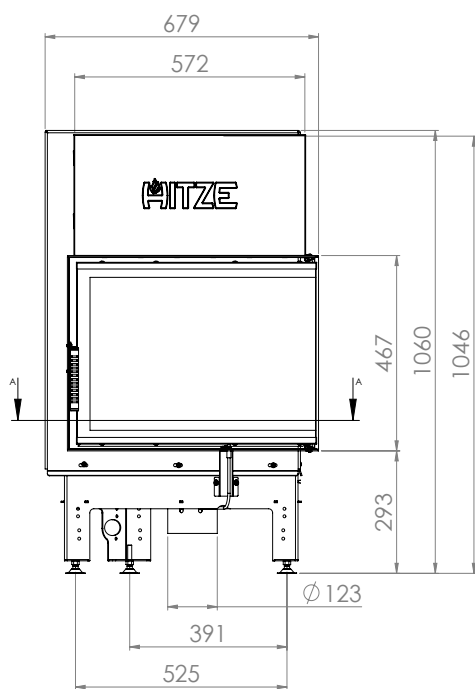

ALBERO

AL11.R.HD